

USER MANUAL

TABLE OF CONTENTS

Section1: General Information	01
1.1 What's in the box?	01
1.2 Safety Warnings and Important Information	01
1.3 Disposal at End-of-Life	03
Section 2: Features	04
2.1 Assembly	04
2.2 Aurorum-1 Diagram	05
2.3 Display Overview	06
2.4 Display Indicators	06
2.5 Display Program Settings.....	13

2.6 Charging	16
2.7 Safety Warning	17
Section 3: Usage	20
3.1 Getting Started.....	21
3.2 Practicing Guidelines	24
3.3 Diagram of Standing and Folding.....	25
Section 4: Maintenance	27
4.1 Cleaning.....	27
4.2 Storage	27
Section 5: Warranty Information	28

SECTION1: GENERAL INFORMATION

Before operating this vehicle, please read all instructions. This User Manual will guide you through the functions, usage, and proper care of your Aurorum. If you have any questions or cannot find the information you need in the manual, please contact your place of purchase or our customer service immediately. Before contacting customer service, please have your model number and purchase information ready as these may be needed during the call. For your convenience, we recommend you to record this information behind this manual's cover.

It is important that you follow all safety warnings that appear throughout this manual and exercise good judgment when using your Aurorum scooter. Consult this manual before you attempt to use your Aurorum. If you have questions not answered by this manual, contact BEDLEM customer service may be reached at 1-844-299-0625.

1.1 WHAT'S IN THE BOX?

- 1x Aurorum-1 Folding Electric Scooter
- 2x Handles
- 1x Charger
- 1x User Manual

1.2 SAFETY WARNINGS AND IMPORTANT INFORMATION

Within this manual, “the Aurorum”, “your Aurorum”, “your scooter” and “the scooter” refer to the Aurorum Folding Electric Scooter. The Aurorum is a personal scooter that uses electrical power. Please note: This technology cannot prevent injury if you do not use the product as indicated in this manual. By riding our Aurorum, the user acknowledges and accepts responsibility of all risks associated with the use of the Aurorum

E-Scooter which may include, but are not limited to, muscle injuries, broken bones, lacerations, serious injury, and possible death, which may be sustained while using the Aurorum.

To better insure your safety, **ALWAYS USE APPROPRIATE PROTECTIVE GEAR**, read and follow all instructions and warnings in the User Manual.



Appropriate protective gear should include an ASTM F1492, F1447, F18981, F1492, Snell B-90A, B-95, N-942, or CPSC approved helmet and other gear including knee and elbow pads.

Use the Aurorum at your own risk. We are not responsible for mishaps due to lack of common sense.

DECLARATION OF CONFORMITY:

This device complies with Part 15 of the FCC Rules.

Operation is subject to the following two conditions: (1) This device may not cause harmful interference, and (2) this device must accept any interference received, including interference that may cause undesired operation.

FCC RELATED INFORMATION:

This equipment has been tested and found to comply with the limits for a Class B digital device, pursuant to Part 15 of the FCC Rules. These limits are designed to provide reasonable protection against harmful

interference in a residential installation. This equipment generates, uses, and can radiate radio frequency energy and, if not installed and used in accordance with the instructions, may cause harmful interference

02

to radio communications. However, there is no guarantee that interference will not occur in a particular installation. If this equipment does cause harmful interference to radio or television reception, which can be determined by turning the equipment off and on, the user is encouraged to try to correct the interference by one or more of the following measures:

- Reorient or relocate the receiving antenna.
 - Increase the separation between the equipment and receiver.
 - Connect the equipment into an outlet on a circuit different from that to which the receiver is connected. ■
- Consult the dealer or an experienced radio/TV technician for help.

The manufacturer is not responsible for any radio or TV interference caused by unauthorized modifications to this equipment. Such modifications could void the user's authority to operate the equipment.

1.3 DISPOSAL AT END-OF-LIFE

This product must not be disposed of by incineration, landfilling, or mixing with household trash. Improper disposal of the battery contained within this product may result in the battery heating up, rupturing, or igniting which may cause serious injury. The substances contained inside the battery present chemical risks to the environment. The recommended disposal for any Aurorum at its end-of-life is to dispose of the entire unit at or through an e-Waste recycling center, program, or facility. Local regulations and laws pertaining to the recycling and disposal of lithium ion batteries and/or products containing them will vary according to country, state, and local governments. You must check laws and regulations corresponding to where you live in order to properly dispose of the battery and/or

unit. It is the user's responsibility to dispose of their waste equipment properly with accordance with local regulations and laws.

For additional information about where you should drop off your batteries and electrical or electronic waste,

03

please contact your local or regional waste-management office, your household waste disposal service, or your point-of-sale.

SECTION 2: FEATURES

Please read the user manual in its entirety before using the Aurorum so that you may fully understand its parts and functions and be able to operate it safely.

2.1 ASSEMBLY

The Aurum comes mostly assembled within the package. Simply screw each handle into each side of the middle connector bar.



Do not perform assembly when the power is on or the battery is charging. Be extra cautious during assembly, otherwise the carbon fiber stem of the Aurum may be scratched.

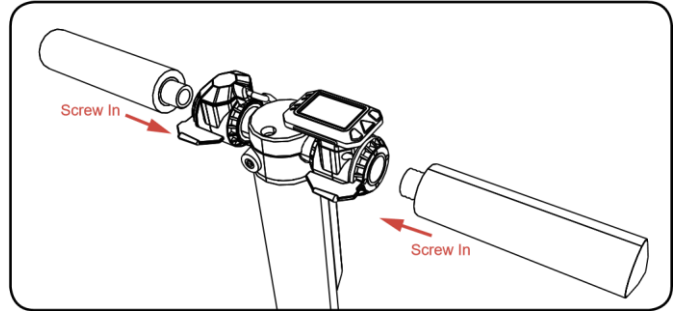

2.2 AURORUM-1 DIAGRAM

1. Handles
2. Display
3. Headlight
4. Handlebar Stem
5. Motorized Front Wheel
6. Sealed Suspension
7. Folding Latch
8. Kickstand
9. Deck
10. Footbrake
11. Wheel
12. Handbrake
13. Charging Port
14. Throttle

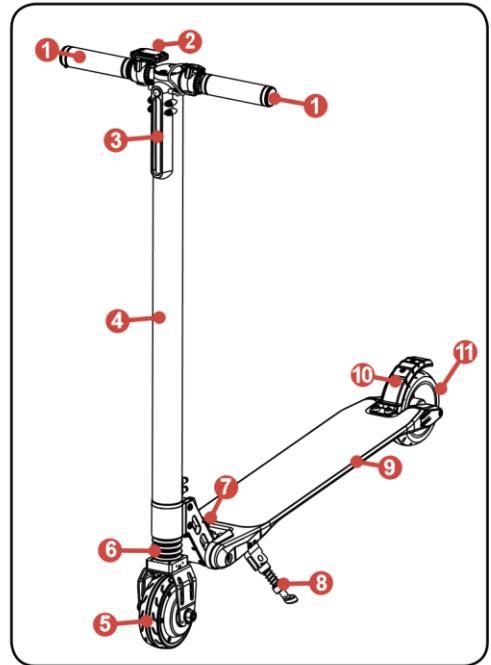
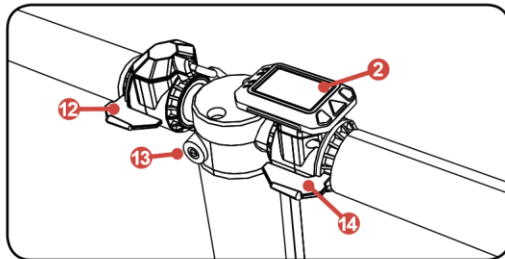

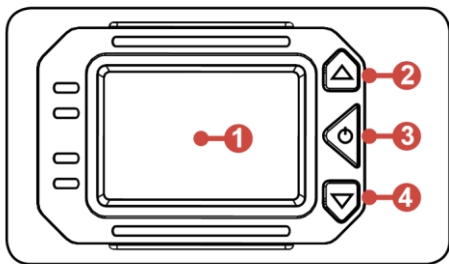

2.3 DISPLAY OVERVIEW

The Aurorum display features many different options and elements. Be sure you understand these before attempting to ride. See the following images and information for details related to each option. Note, these areas are related to features noted in the next section.

Press and hold the **POWER** button to turn on the display.

The display is made up of these parts:

- | | |
|-----------|---------------|
| 1. Screen | 2. Up Arrow |
| 3. Power | 4. Down Arrow |

DO NOT expose the display to direct sunlight or high heat for extended periods of time.

DO NOT store the Aurorum inside a vehicle or other location subject to high heat. Any of these conditions may damage the display's interface.



2.4 DISPLAY INDICATORS

To navigate through the display use the **UP ARROW** and **DOWN ARROW** button.



After 10 minutes of non-use, the display will turn itself off which will also prompt the Aurorum to turn off. The auto shutoff time may be adjusted as desired. Please refer to P 03 in Section 2.5.

General Indicators:

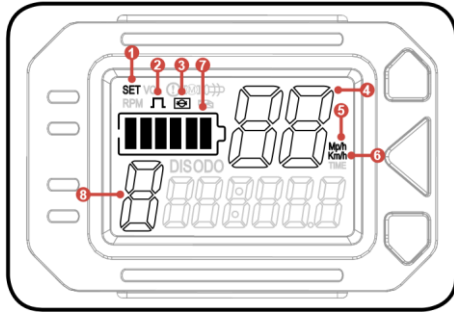

1. **Setting:** This icon will appear when modifying program settings. Please see **DISPLAY MODE INDICATORS** for more information on these settings.

2. **Magnetic Settings:** This icon is related to magnetic settings. It should not appear under normal circumstances.

3. **Wheel Diameter:** This icon is related to wheel diameter and the Aururum's motor. It should not appear under normal circumstances.

4. **Speed:** These numbers indicate current speed readings and will change as the Aururum is in use.

5. **Miles per Hour (MPH or Mp/h):** This icon indicates odometer readings and will appear if you have selected speed to display with this unit of measurement.

6. **Kilometers per Hour (KPH or km/h):** This icon indicates odometer readings and will appear if you have selected speed to display with this unit of measurement.

7. **Battery Level:** This icon indicates battery power level. As power goes down, the icon will indicate different levels.



When the battery level is low, stop riding, turn off the Aururum, and fully recharge it before riding again.

8. **Gear Position:** This icon indicates current gear. There are 5 gears. Gear 1 has an approx. speed range of 0-5mph (0-8km/h). Gear 2 has an approx. speed range of 0-7.5mph (0-12km/h). Gear 3 has an approx. speed range of 0-

10mph (0-16km/h). Gear 4 has an approx. speed range of 0-12.5mph (0-20km/h). Gear 5 has an approx. speed range of 0-15mph (0-24km/h). Use the **UP ARROW** and **DOWN ARROW** buttons to adjust gears as desired.

07

Fault Indicators:

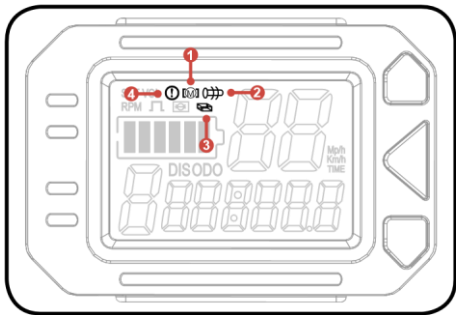

There are four icons which will appear under abnormal circumstances and/or if the internal system or parts inside the Aurorum encounter some type of issue. Read the information below to understand what each icon relates to.

In the event that any of these icons appears, attempt to turn the Aurorum off and back on again.



If turning the Aurorum off and back on again doesn't resolve the issue, please contact customer service.

- 1. Motor Failure:** The icon indicates motor activity and will appear if an element of the motor fails to function properly. If the issue is resolved and/or there are no issues with any element of the motor, the icon will not appear.
- 2. Handle Failure:** The icon indicates handling activity and will appear if an element of the steering fails to function properly. If the issue is resolved and/or there are no issues with any element of the scooter's handling, the icon will not appear.
- 3. Control Failure:** This icon indicates a serious internal issue with the Aurorum's components. If this icon appears, immediately stop using the Aurorum and contact customer service.

4. **Brake Failure:** This icon indicates abnormal brake activity and will appear if an element of the brakes fails to function properly. If the issue is resolved and/or there are no issues with any element of the brakes, the icon will not appear.

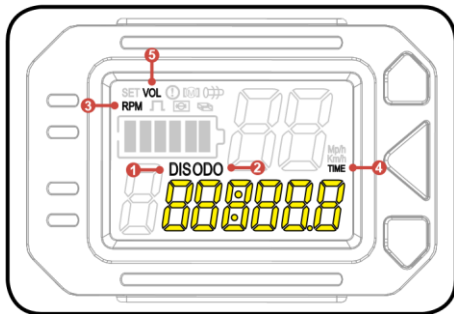

display.

5. Display Indicators & Modes

Different modes and their related settings may be shown on the display as desired. To switch between modes and display different information, briefly press the **POWER** button.

1. **Distance:** When this mode is selected, the distance icon and the corresponding value will appear on the highlighted area on the display. This icon is related to tracking the distance you travel per trip. To reset, turn the Aurorum off and/ or press and hold the **UP ARROW BUTTON**.

2. **Odometer:** When this mode is selected, the odometer icon and the corresponding value will appear on the highlighted area on the

3. **Rotation Speed:** When this mode is selected, the RPM icon and the corresponding value will appear on the highlighted area on the display.

4. **Time:** When this mode is selected, the time icon and the corresponding value will appear on the highlighted area on the display. This icon is related to tracking the time you travel per trip. To reset, turn the Aurorum off.

6. **Voltage:** The icon will show upon start-up. The voltage is related to internal settings within the scooter and is not accessible.

2.5 DISPLAY PROGRAM SETTINGS

The display features 5 program settings which are not readily indicated on the screen by default. To access settings, press and hold the **UP ARROW** and **DOWN ARROW** button simultaneously then press the **POWER** button to cycle between settings. For each setting, use the **UP ARROW** and **DOWN ARROW** button to adjust options or levels according to which setting you are modifying. To exit settings, simply press and hold the **UP ARROW** and **DOWN ARROW** button simultaneously or refrain from pressing any button and the display will time out and return to the main interface on its own. See the following information for details related to each setting.

P 01: Backlight Brightness Setting

This setting is for display's backlight brightness. Brightness may be set to 3 different intensities.

P 02: Measurement Setting

This setting determines the unit of measurement in which your current speed is displayed. Speed may be displayed in either miles per hour (MPH or Mp/h) or kilometers per hour (KPH or Kp/h). By default, this setting is at 0, with the measurement being kilometers per hour (KPH or Kp/h). If changed, the display will show the related icon.

P 03: Automatic Shutoff Time Setting

This setting is for the automatic shutoff time. Time may be set to any 5 minute increment between 0 and 60 (i.e. 5 for 5 minutes, 10 for 10 minutes). By default, the timer is set to 10 minutes. Selecting 0 will turn this feature off.

P 04: Manual Acceleration Start Setting

This setting is related to voltage and effects acceleration. Levels may be set to 0 or 1. By default, this setting is at 0. Selecting 0 will turn this feature off meaning you may use the throttle to immediately

accelerate meaning you are not required to manually generate power. Selecting 1 will turn this feature on meaning you will need to generate power yourself (and build up voltage) before the throttle may be used. This setting may be changed as desired. Note, selecting 1 may improve battery life as using self-power helps conserve some power. For details on the different ways to accelerate, please see Section 3.1.

P 05: Cruise Control

This setting is for the Cruise Control feature. Levels may be set to 1 or 2. By default, this setting is at 1. Selecting 1 turns the feature off. Selecting 2 turns the feature on.

P 06: Odometer (ODO)

The setting is related to odometer readings. When this mode is selected, the odometer icon and the corresponding value will appear on the display.

2.6 CHARGING



CHARGE THE AURORUM BEFORE USING IT.

The charge cycle is complete when the battery icon on the display is full and/or the charger's light is green. After this initial charge, use the scooter until battery level reaches approximately 10% (Battery Level indicator will show one bar) before recharging.

Each charge cycle from zero to full charge will take approximately 1.5 hrs. When the backlit display on the handlebars indicates battery power is low, recharge the Aurorum. To recharge the Aurorum, use the included charging cable and its adapter.

Step 1. Ensure the scooter is turned off before charging and remains off while charging.

Step 2. Remove the cap covering the charger port.

Step 3. Insert the appropriate end into the scooter's stand and then insert other end into a wall outlet.

Step 4. While the scooter is charging, the charger light will be red.

Step 5. When the scooter is fully recharged, the charger light will turn green. You may then disconnect the scooter from the charger.



DO NOT under any circumstances use the scooter while it is charging or connected to the charger.



The charging time is approximately 1.5 hours. Charging longer than that may affect battery life and/or performance. If the charger's light doesn't turn on, it may not be fully connected. Check that it is securely connected to the wall and to the scooter.

2.7 SAFETY WARNING

When Using the Battery

1. Misusing the battery may cause the battery to get hot, rupture, or ignite and cause serious injury. Be sure to follow the safety rules listed below:
 - Do not place the battery in fire or direct contact with heat.

- Do not pierce the battery with sharp objects, strike the battery with a hammer, step on the battery, or otherwise subject it to strong impacts or shocks.
 - Do not expose the battery to water or any liquids, or allow the battery to get wet.
2. Do not disassemble or modify the battery. The battery contains safety and protection devices which, if damaged, may cause the battery to generate heat, rupture or ignite.
 3. Do not place the battery on or near fires, stoves, or other high-temperature locations. Do not place the battery in direct sunlight, or use or store the battery inside cars in hot weather. Using the battery in this manner may also result in a loss of performance and a shortened life expectancy.



- 1. If the device is to be used by children, the caregiver should explain the contents of the user manual to the children. The caregiver should provide adequate supervision to ensure that the device is being used as explained in the user manual.**
- 2. Immediately discontinue use of the battery if, while using, charging, or storing the battery, the battery emits an unusual smell, feels hot, changes color, changes shape, or appears abnormal in any other way.**

3. Do not place the batteries in microwave ovens, high-pressure containers, or on induction cookware.

4. In the event that the battery leaks and the fluid gets into one's eye, do not rub the eye. Rinse well with water and immediately seek medical care. If left untreated, the battery fluid could cause damage to the eye.

While Charging

(1) Be sure to follow the rules listed below while charging the battery. Failure to do so may cause the battery to become hot, rupture or ignite and cause serious injury. When charging the battery, use a specified battery charger provided in the package. Do not place the battery in or near fire, or under direct sunlight.

(2) Do not continue charging the battery if it does not recharge within the specified charging time. Doing so may cause the battery to become hot, rupture or ignite.

The temperature range within which the battery can be charged is 32°F ~ 104°F (0°C to 40°C). Charging the battery at temperatures outside of this range may cause the battery to become hot or to break, also harm the performance of the battery or reduce the battery's life expectancy.

When Discharging the Battery

Do not discharge the battery using any device except for the specified device. When the battery is used in devices aside from the specified device it may damage the performance of the battery or reduce its life expectancy, and if the device causes an abnormal current to flow, it may cause the battery to become hot, rupture or ignite and cause serious injury.

SECTION 3: USAGE

We sincerely hope every operator can ride the Aurorum safely. Think back to when you first learned to ride a bike, a car or skateboard. Note the following information before attempting to ride your Aurorum.



- Protective gear including a ASTM F1492-approved helmet must be worn at all times

- The Aurorum supports up to 250 lbs. (113 kg)



- Only operate the Aurorum where permitted. Local laws may restrict where you may ride.

The Aurorum contains a motor and may be classified as a motor vehicle under your local law. It is your responsibility to understand and abide by any local laws restricting how or where you may ride.

3.1 GETTING STARTED

Assuming you have equipped suitable protective gear and that the Aurorum has been placed on a level surface, is well charged, and does not have any issues, follow the steps below. For your safety, please carefully read this entire section before attempting to ride.

The **Manual Acceleration Start** feature is off by default which means you may use the throttle immediately for powered acceleration. If it is on, you will need to step and kick off the ground to begin **Manual Acceleration Start** before the throttle may be used.

Regardless of start type, **Cruise Control** may be used any time after you've started using the throttle. See the instructions below.

Powered Acceleration Start

This is the default start setting. Follow the instructions below.

Step 1. Press the **POWER** key for 2 seconds to turn the scooter on.

Step 2. Carefully step on with one foot and stand upright but relaxed.

Step 3. Balance with both feet on the scooter and use the throttle to start powered acceleration.

Step 4. To stop riding, release the throttle and use the handbrake, footbrake, or both to gradually coast to a stop then step off the scooter one foot at a time. Be extra cautions when dismounting for the first time.

Manual Acceleration Start

To use this start setting, please refer to **P 04** in Section 2.5 then follow the instructions below.

Step 1. Press the **POWER** key for 2 seconds to turn the scooter on.

Step 2. Carefully step on with one foot and stand upright but relaxed.

Step 3. Keep one foot on the ground and kick off to begin accelerating manually.

Step 4. Once the Aurorum reaches approximately 4 mph (6km/h), press the throttle to start powered acceleration.

Step 5. To stop, release the throttle and use the handbrake, footbrake, or both to gradually coast to a stop then step off the scooter one foot at a time. Be extra cautions when dismounting for the first time.

Cruise Control

Step 1. Accelerate to reach the desired speed.

Step 2. Hold the throttle for approximately 6 seconds to turn on Cruise Control and maintain speed.

Step 3. Use the throttle or the handbrake to turn off Cruise Control.

While riding, you can use the front headlight to improve visibility if needed. To use the light, simply press the button just above the light to turn it on or off.



Using the headlight for extended periods of time may affect scooter's overall battery life.

3.2 PRACTICING GUIDELINES

Practice until you are comfortable with using all of the Aurorum scooter's functions. See the following tips below.

- Wear casual clothing and flat shoes to maintain your flexibility and stability.
- Practice until you can easily get on, move forward, turn, stop, and dismount with ease.
- Make sure the pavement is even. Do not operate on a slope until you are experienced.
- The Aurorum is designed for relatively smooth, flat terrain. When driving on uneven terrain, the user should slow down.
- Until you are comfortable using the scooter, avoid operating in places with pedestrians or obstacles.



The Aurorum weights approximately 15 lbs (7 kg). If you are unsure of your ability to lift it with one hand, please lift it with both hands or have second person help.

3.3 DIAGRAM OF STANDING AND FOLDING

The scooter includes a kickstand. Before using the kickstand, bring the scooter to a complete stop and turn it off. Before riding the scooter again, lean the scooter off the kickstand and push the kickstand up.

Standing

1. Locate the kickstand on the side of the scooter's deck.
2. Push the kickstand down and away from the scooter. Then carefully lean the weight of the scooter onto the kickstand.

Folding

- a. Locate the latch at the base of the scooter's stand.
- b. Holding the latch open, grasp the stand firmly and pull it down until it and the deck are parallel.



Before moving, lifting, or otherwise transporting the scooter, please make sure you have turned it off. Fold the scooter and grasp it firmly before lifting and/or moving it.

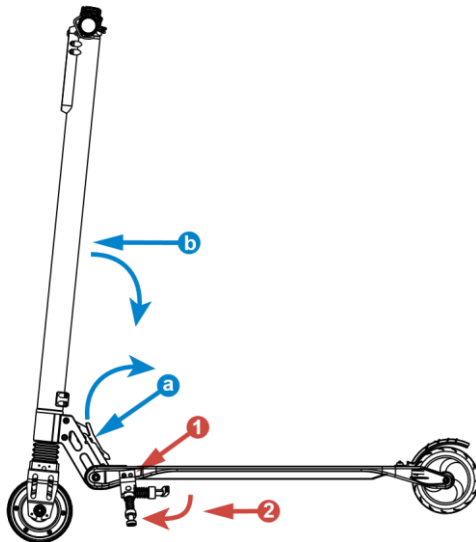

SECTION 4: MAINTENANCE

4.1 CLEANING

The Aurorum may need cleaning after riding for extended periods of time. See the following tips below.

- Completely power off the scooter before cleaning.
- Use dry, non-abrasive cloth to gently remove debris or dust.
- The Aurorum may not come in contact with it in any kind of liquid.
- Never use alcohol or ammonia-based cleaning solutions.
- Never spray liquid directly onto any part of the scooter.

4.2 STORAGE

The Aurorum may be stored easily when not in use. See the following information below.

- Before storing, fully charge the Aurorum to prevent battery over-discharge due to non-use.
- Cover the Aurorum to protect it from dust. Do not store in a dusty environment as, with all electronic devices, this may cause damage over time
- Store the Aurorum indoors at suitable temperatures between -10°F to 113°F (-23°C to 45°C).

- If storing for more than one month, discharge and recharge the battery every three months.
- DO NOT store in an unheated garage, shed, or other location with extreme temperature fluctuations or ranges. **Do not perform any maintenance when the power is on or the battery is charging. Do not let water or liquids get into the Aurorum. It will cause permanent damage to the internal electronic components.**



SECTION 5: WARRANTY INFORMATION

Your BEDLEM® Aurorum-1 Folding Electric Scooter (“Product”) includes a One Year Limited Hardware Warranty (“Warranty”). The Warranty covers product defects in materials and workmanship under normal use. This Warranty is limited to residents of the United States and Canada only and is available only to original purchasers. This Warranty gives you specific legal rights and you may also have other rights which vary from state to state.

This Warranty starts on the date of your purchase and lasts for one year (the “Warranty Period”). The Warranty Period is not extended if the Product is repaired or replaced. We may change the availability of this limited warranty at our discretion, but any changes will not be retroactive.

Warranty services are provided by BEDLEM®. If a hardware defect arises and a valid claim is received within the Warranty Period, at its option and to the extent permitted by law, BEDLEM® will: (1) repair the hardware defect by using new or refurbished parts that are equivalent to new in performance and reliability; or (2) exchange the Product with a product that is new or refurbished which is substantially equivalent to the original product. This Warranty is for one replacement only of like-items and does not cover items out of production if the product is no longer made or stocked. This Warranty is not assignable or transferable. The original purchaser may call BEDLEM's toll-free number at 1-844-299-0625 for service requests.

When a product or part is exchanged, any replacement item becomes your property and the replaced item becomes BEDLEM's property. This warranty only covers technical hardware defectiveness during the warranty period and under normal use conditions. BEDLEM® does not warrant uninterrupted or error-free operation of this Product.

This Warranty does not cover any damage due to: (a) transportation; (b) storage; (c) improper use; (d) failure to follow the product instructions or to perform any preventive maintenance; (e) modifications; (f) unauthorized repair; (g) normal wear and tear; or (h) external causes such as accidents, abuse, or other actions or events beyond our reasonable control.

Important: Do not disassemble the Product. Disassembling the Product will void this Warranty. Only BEDLEM® or a party expressly authorized by BEDLEM® should perform service on this Product.

DISCLAIMER OF WARRANTY: THE REMEDIES DESCRIBED ABOVE ARE YOUR SOLE AND EXCLUSIVE REMEDIES AND OUR ENTIRE LIABILITY FOR ANY BREACH OF THIS LIMITED WARRANTY. OUR LIABILITY SHALL UNDER NO CIRCUMSTANCES EXCEED THE ACTUAL AMOUNT PAID BY YOU FOR THE DEFECTIVE PRODUCT, NOR SHALL WE UNDER ANY CIRCUMSTANCES BE LIABLE FOR ANY CONSEQUENTIAL, INCIDENTAL, SPECIAL OR PUNITIVE DAMAGES OR LOSSES, WHETHER DIRECT OR INDIRECT.

SOME STATES DO NOT ALLOW THE EXCLUSION OR LIMITATION OF INCIDENTAL OR CONSEQUENTIAL DAMAGES, SO THE ABOVE LIMITATION OR EXCLUSION MAY NOT APPLY TO YOU. THE DURATION AND REMEDIES OF ALL IMPLIED WARRANTIES, INCLUDING WITHOUT LIMITATION THE WARRANTIES OF MERCHANTABILITY AND FITNESS FOR A PARTICULAR PURPOSE ARE LIMITED TO THE DURATION OF THIS EXPRESS LIMITED WARRANTY.